

Letter to Mr. and Mrs. Miller

Dear Mr. and Mrs. Miller, _____ 5

We're writing this letter to tell you that we hit our _____ 16
baseball through your window while you were out. _____ 24

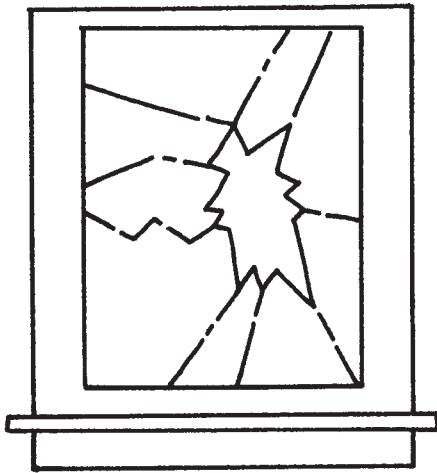

We didn't mean to do it. Jake _____ 31
was working on his pop fly balls. _____ 38
He'll need more work with fly _____ 44
balls, I'd have to say. But don't _____ 51
worry. We won't be hitting the _____ 57
ball your way again. _____ 61

We know we should've hit the baseball into the _____ 70
woods. But Jake couldn't stand the thought of _____ 78
hitting the ball over there. He thought we'd never _____ 87
find it again. _____ 90

You're the best people in our neighborhood. We'd _____ 98
like to make it up to you. Let's work out a plan. _____ 110
We'll work for you until we've earned the price _____ 119
of fixing your window. _____ 123

Sam and Jake _____ 126



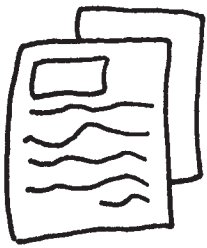

Recycle and Make Less Trash

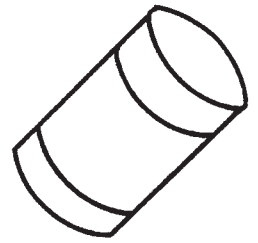

Did you know that we could make our world a better place? When we throw away our trash, we shouldn't be foolish. Some people don't know it, but they'll throw away a ton of trash each year. That'll pile up!

It doesn't have to be this way. We can make less trash and recycle. When we recycle something it'll become something new. We can recycle glass, cans, paper, and other things. It's important to take care of our world. That's why we shouldn't throw away things that we can recycle.

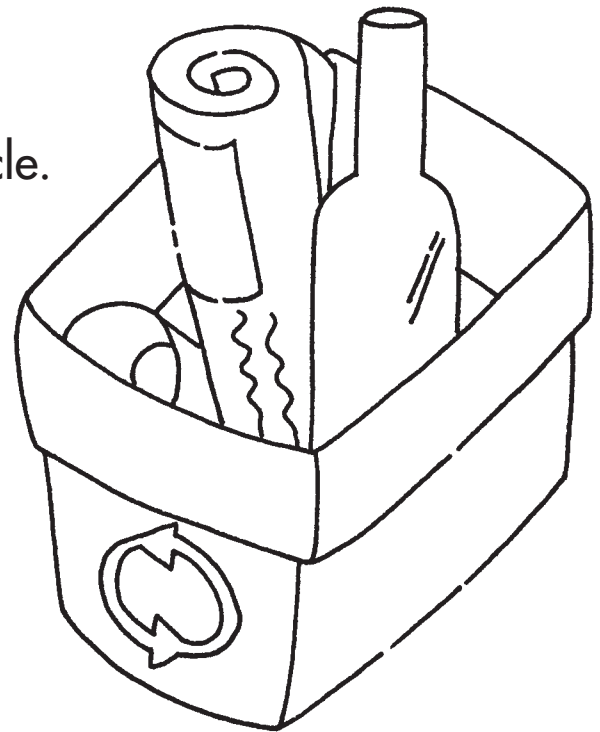

If people didn't recycle there'd be too much trash! Trash piles would grow and grow. Our living spaces wouldn't grow. They'd get smaller and smaller. So think before you throw something out. You could be looking at an old can that'll become a new can one day!



Frog Classroom Rules



"Take out a piece of paper," said Mrs. Frog. "It's time to write down the rules of the classroom."

Mrs. Frog was sick last week. She doesn't know how the frogs could've misunderstood the rules.

"Rule number one," she started. "Little frogs shouldn't catch flies during class time. No eating in class! Rule number two: little frogs mustn't hop around the room."

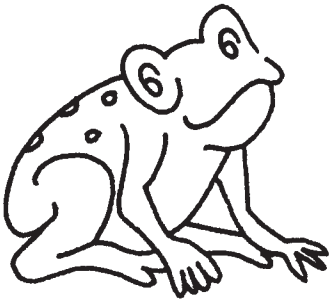

The little frogs wrote down all the rules. Then little frog Sally said, "We won't disobey next time."

"You're right to admit your mistake. You could've been kept after school," said Mrs. Frog. "Now let's go to the playground for a hop!"

